



VIBROMATIC

COMPANY, Inc.

1301 S. 6th St. ~ Noblesville, IN 46061-1358
 Phone (317) 773-3885 Fax (317) 773-2342

WLPS-12

The force used to power the WLPS Drive Unit is accomplished by using one or more electromagnetic coils which act upon pole face plates to generate vibratory motion. The upper and lower members of the drive unit are constrained by leaf springs causing torsional vibration which is transferred to the top member in the form of feed motion. When the drive unit moves the parts at maximum efficiency with minimum current effort, the unit is said to be tuned to a natural frequency of the power source. The mass and diameter of the feeder bowl is the determining factor in tuning the unit.

TUNING

Tuning an inline to proper frequency involves the proper proportions between the mass and the springs. The natural frequency of the inline should be as close as possible to the 60 cycle (rectified) or 120 cycle running frequency of the coil.

When springing an inline unit, maintain equal springing in all spring packs if possible. If you add a spring to one side, the next spring should be placed exactly opposite. Also, keep the thickest springs nearest the mounting point.

Inline units have fairly wide range between the lowest and highest points of the tuning and should be finally tuned with the inline carrying a normal load of parts and running at the slowest possible control setting, while maintaining the specific rate.

MOUNTING

The vibratory drive unit should be installed on a table with a heavy top and legs to prevent the mounting surface from absorbing the vibration. We normally use a minimum of 1" thick steel plate with legs of 3" square tubing. All legs must be leveled and positioned on a solid floor. The vibratory feeder cannot strike anything or have its vibration restricted in any manner. The mounting feet built into our standard unit should be bolted to this suitable mounting surface.

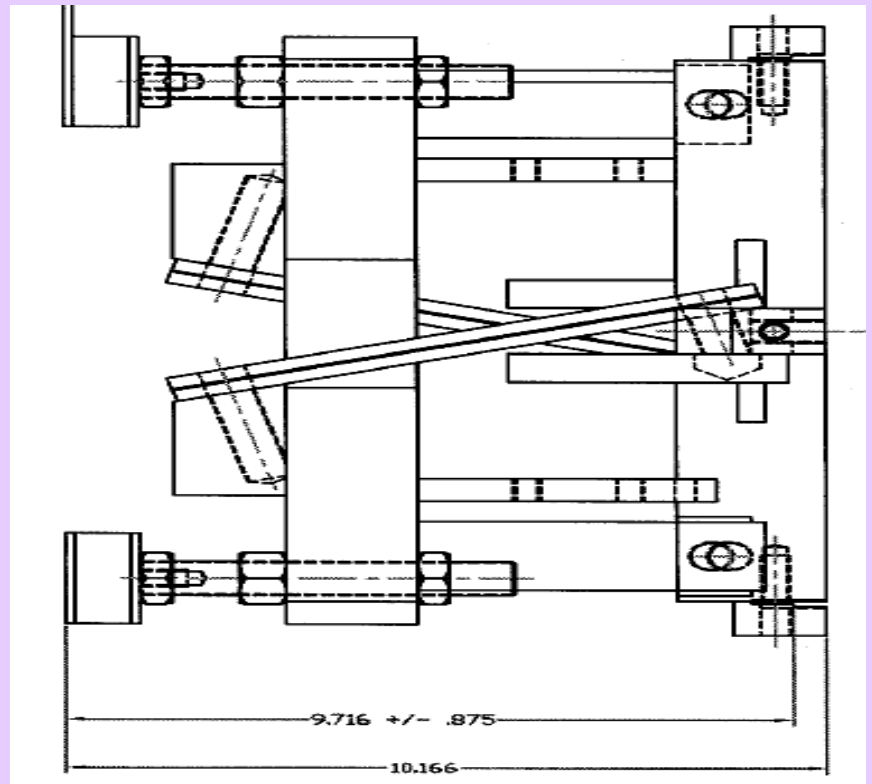
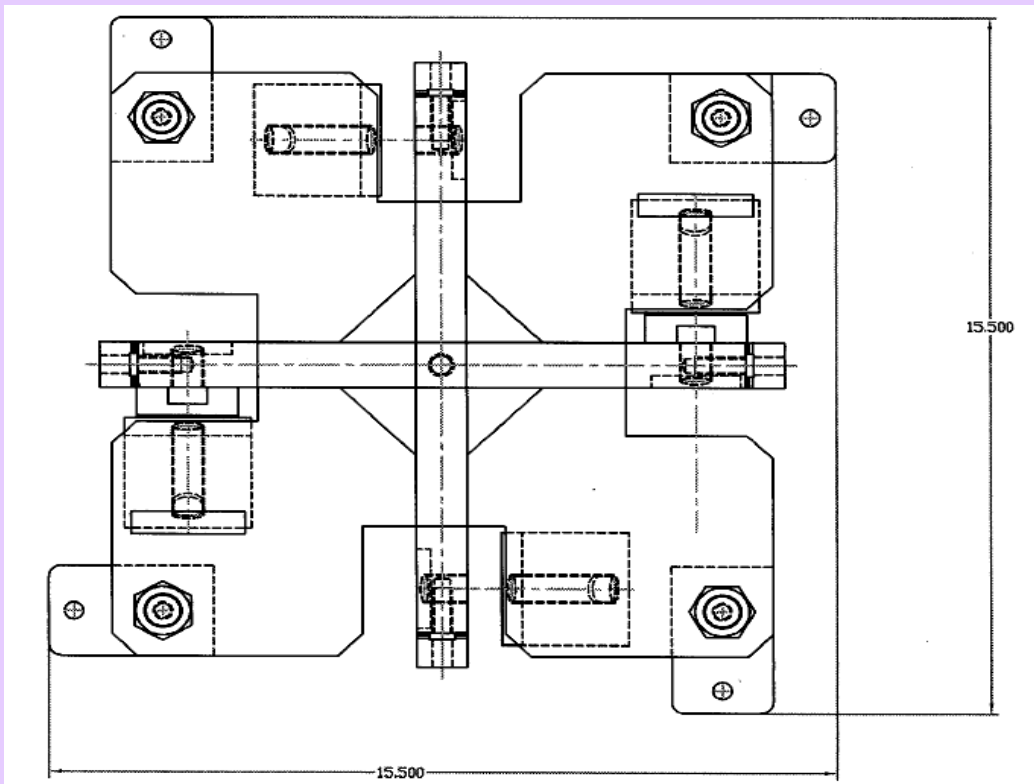

Spare Parts	
Part Number	Description
F-120V	Vibratory Coil (120 Volt)
F-240V	Vibratory Coil (240 Volt)
LP-1212	1/8" Feeder Spring
LP-1213	3/16" Feeder Spring
LP-1214	1/4" Feeder Spring
LP-1215	5/16" Feeder Spring
LP-1216	3/8" Feeder Spring